

- NOTE :**
1. DIMENSIONS ARE AS PER IS:1231
  2. DEGREE OF PROTECTION / COOLING: IP:55/IC:411.
  3. TERMINAL BOX CAN BE ROTATABLE THROUGH 360° IN STEPS OF 90°.
  4. KEY & KEYWAY ARE AS PER IS:2048 & TOLERANCE ON KEYWAY IS P9.
  5. PROTECTED CENTRE HOLE AT SHAFT EXTENSION AS PER IS:2540. M20X40
  6. \* OPTIONAL INCASE OF DOUBLE SHAFT EXTENSION
  7. UNLESS OTHERWISE SPECIFIED TERMINAL BOX WILL BE ON RHS WITH SINGLE SHAFT EXTENSION

|        |       |    |     |    |    |    |      |      |
|--------|-------|----|-----|----|----|----|------|------|
| RC315L | 4,6&8 | 80 | 170 | 22 | 85 | 14 | 1505 | 1685 |
|        | 2     | 65 | 140 | 18 | 69 | 11 | 1475 | 1625 |
| FRAME  | POLE  | D  | E   | F  | GA | GD | L    | LC   |

**TERMINAL BOX ARRANGEMENT**

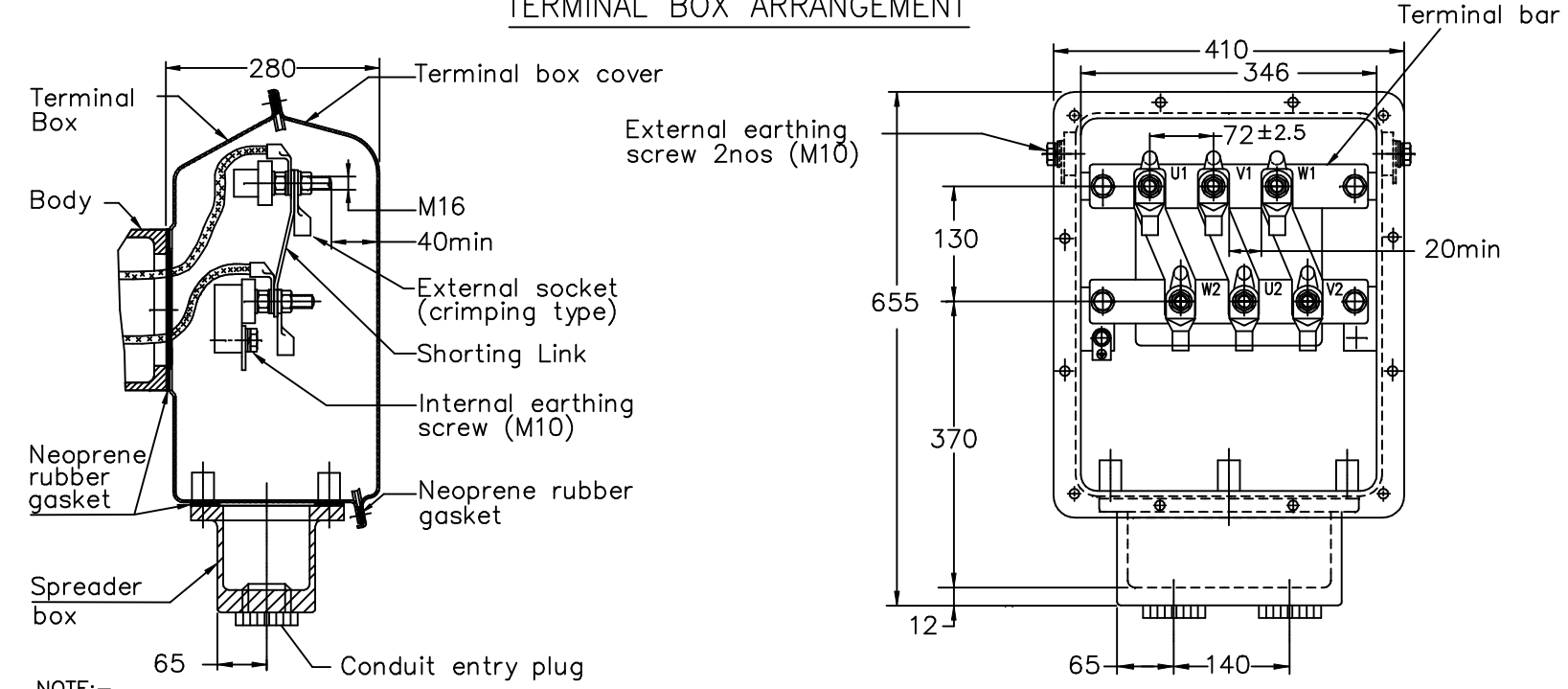

- NOTE:-**
1. MINIMUM ELECTRICAL CLEARANCE AND CREEPAGE DISTANCES ARE AS PER BS: 4999, PART-145.
  2. MAX. CABLE SIZE:- 2 OF 3 C x Sq.mm AYFY.

|   |  |   |  |  |  |
|---|--|---|--|--|--|
| ITEM/TAG No.  |  | PROJECT :   |  | JOB No.  |  |
| RATING  |  | CONSULTANT  |  | CUSTOMER / O/A No.                                     |  |
| CABLE SIZE  |  |   |  | SCALE  |  |
| R2  |  | RC250 SIZE T.BOX LOCATED ON TOP SIDE OF MOTOR REMOVED         |  | DRAWN KKH 03.03.16                                     |  |
| 1   |  | FRAME DESIGNATION RC315L WAS RC315LX AND TABLE FOR LX REMOVED |  | CHECKED VSH 03.03.16                                   |  |
| REV. ZONE   |  | BRIEF RECORD  |  | APPROVED RNV 03.03.16                                  |  |
| ALL INFORMATION CONTAINED IN THIS DOCUMENT IS CONFIDENTIAL AND THE PROPERTY OF KIRLOSKAR ELECTRIC CO. LTD. REPRODUCTION OF THESE IN ANY FORM IS TO BE DONE WITH THE SPECIFIC PERMISSION OF THE COMPANY. |  | DRAWING No.   |  | SIGNATURE DATE   |  |
| PRINTS ISSUED TO  |  | THIS SUPERSEDES   |  | TITLE: RC315L (DOUBLE ENTRY WITHOUT GLAND)             |  |
|   |  | THIS IS SUPERSEDED BY   |  | DIMENSION SHEET  |  |
|   |  |   |  | KHD61550 R2  |  |
|   |  |   |  | SHEET NO. ONE OF ONE                                   |  |
|   |  |   |  | KIRLOSKAR ELECTRIC COMPANY LTD. HUBLI - 580030 (INDIA) |  |