

DO NOT SCALE THE DRAWING

ALL DIMENSIONS ARE IN mm UNLESS OTHERWISE STATED

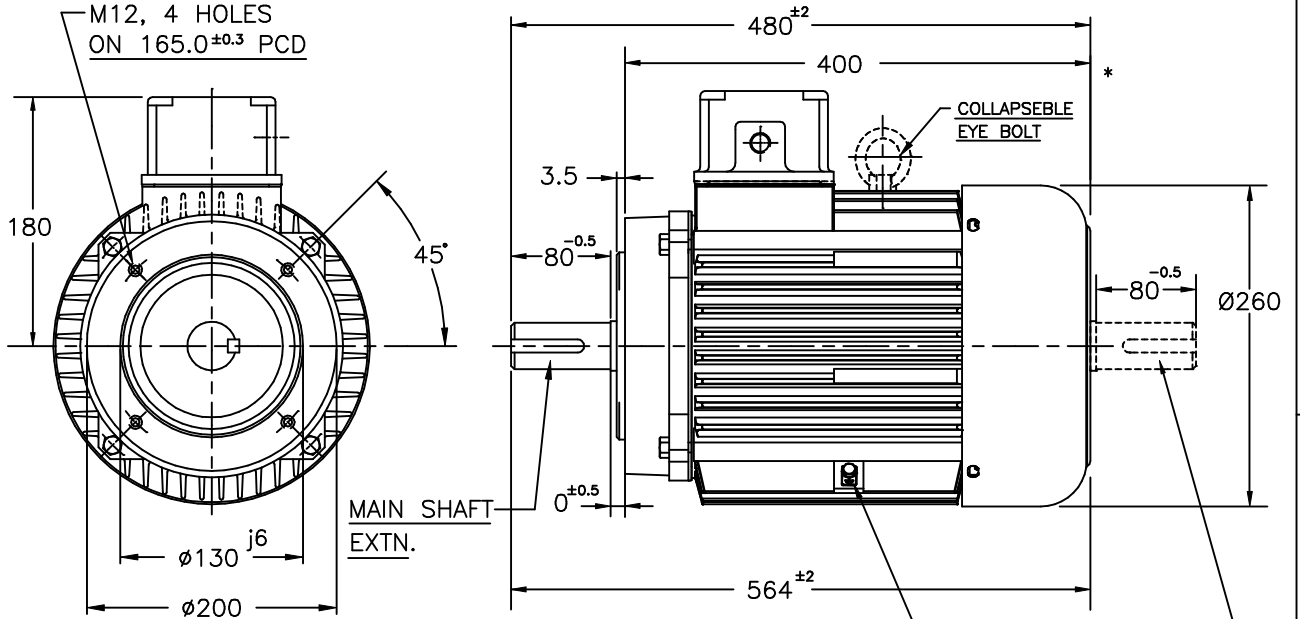

NOTE :

1. DIMENSIONS ARE AS PER IS:1231 & 2223
2. DEGREE OF PROTECTION: IP:55.
3. TERMINAL BOX CAN BE ROTATABLE THROUGH 360° IN STEPS OF 90°.
4. KEY & KEYWAY ARE AS PER IS:2048 & TOLERANCE ON KEYWAY IS P9.
5. PROTECTED CENTRE HOLE AT SHAFT EXTENSION AS PER IS:2540.-M12X28.
6. *OPTIONAL IN CASE OF DOUBLE SHAFT EXTENSION
7. UNLESS OTHERWISE SPECIFIED MOTOR WILL BE WITH SINGLE SHAFT EXTENSION

TERMINAL BOX ARRANGEMENT

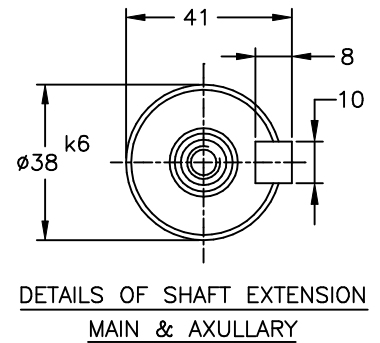
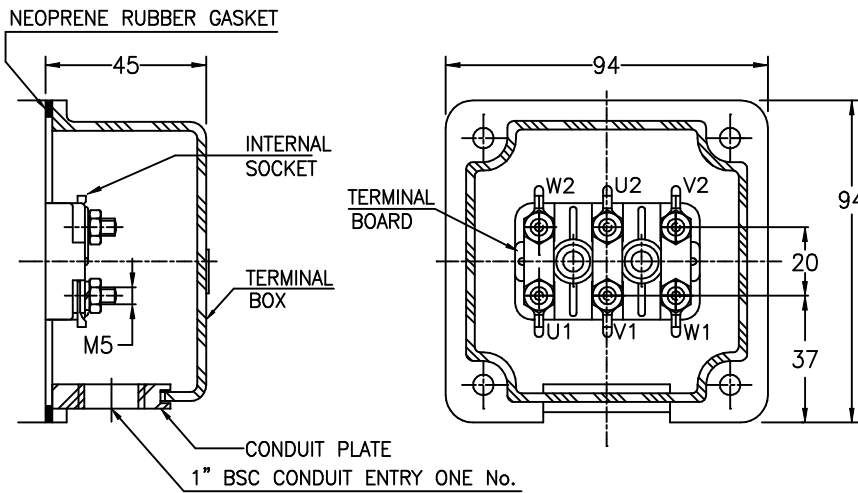

IF IN DOUBT ASK ENGINEERING
 ALL INFORMATION CONTAINED IN THIS DOCUMENT IS CONFIDENTIAL AND THE PROPERTY OF KIRLOSKAR ELECTRIC CO. LTD. REPRODUCTION OF THESE IN ANY FORM IS TO BE DONE WITH THE SPECIFIC PERMISSION OF THE COMPANY.
 SIGN & DATE.
 FROM dt.
 DRAWING No.
 THIS SUPERSEDES THIS IS SUPERSEDED BY

D
 C
 B
 A
 FORM No. 02 201 050 (ISSUE 8)

| | | | |
|--------------|------------|--|--|
| ITEM/TAG No. | PROJECT : | | |
| RATING | CONSULTANT | | |
| CABLE SIZE | JOB No. | | |

| | | | | | |
|---|------|---------------------------------------|-----------|---|-------------------|
| REV. | ZONE | BRIEF RECORD | SIGNATURE | DATE | PRINTS ISSUED TO. |
| CUSTOMER / O/A No. | | SCALE | DRAWN | SPC | 26.5.2016 |
| USED ON / TYPE | | NTS | CHECKED | Vishnu.S.H | 26.5.2016 |
| | | | APPROVED | RNV | 26.5.2016 |
| TITLE: | | DRG. NO. | | KHD61104 | |
| CRC132 (NYLON TERMINAL BOX) | | SHEET NO.....ONE..... OF.....ONE..... | |  | |
| KIRLOSKAR ELECTRIC COMPANY LTD. HUBLI - 580 030 (INDIA) | | | | | |