

UNMENTIONED TOLERANCES

LINEAR DIMENSIONS (UP TO 6)	± 0.1
LINEAR DIMENSIONS (6 TO 315)	± 0.15
LINEAR DIMENSIONS (315 TO 1000)	± 0.2
LINEAR DIMENSIONS (1000 TO 2000)	± 0.3
LINEAR DIMENSIONS (2000 TO 10000)	± 0.5
ANGLES	± 1/2°

ALL INFORMATION CONTAINED IN THIS DOCUMENT IS CONFIDENTIAL AND THE PROPERTY OF KIRLOSKAR ELECTRIC CO. LTD. REPRODUCING OF THESE IN ANY FORM IS TO BE DONE WITH THE SPECIFIC PERMISSION OF THE COMPANY.

SURFACE ROUGHNESS (MAX) AS PER KSD-02-027

RM	50	2.5	25	1.6	3.2	6.3	0.2	0.4	0.8	0.025	0.05	0.1
OLD	✓	✓	✓	✓	✓	✓	✓	✓	✓	✓	✓	✓
NEW	✓	✓	✓	✓	✓	✓	✓	✓	✓	✓	✓	✓

UC: UNMENTIONED CHAM: RAD: 8 7 6 5

DIMENSION DRAWING

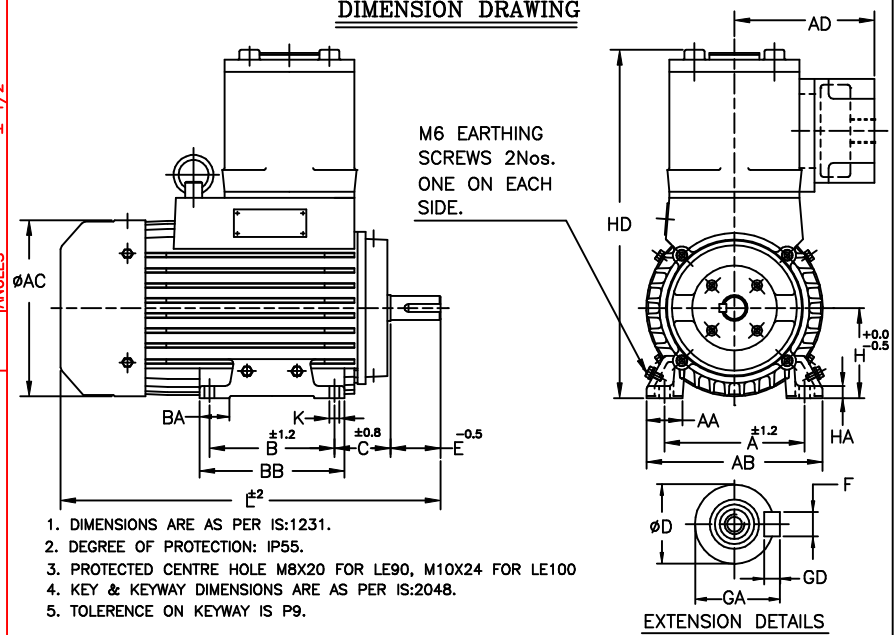

1. DIMENSIONS ARE AS PER IS:1231.
2. DEGREE OF PROTECTION: IP55.
3. PROTECTED CENTRE HOLE M8X20 FOR LE90, M10X24 FOR LE100
4. KEY & KEYWAY DIMENSIONS ARE AS PER IS:2048.
5. TOLERANCE ON KEYWAY IS P9.

ITEM/TAG No.			
RATING			
CABLE SIZE			
O/A NO.:	CUSTOMER :		
PROJECT :	CONSULTANT :	JOB No. :	

TERMINAL BOX ARRANGEMENT

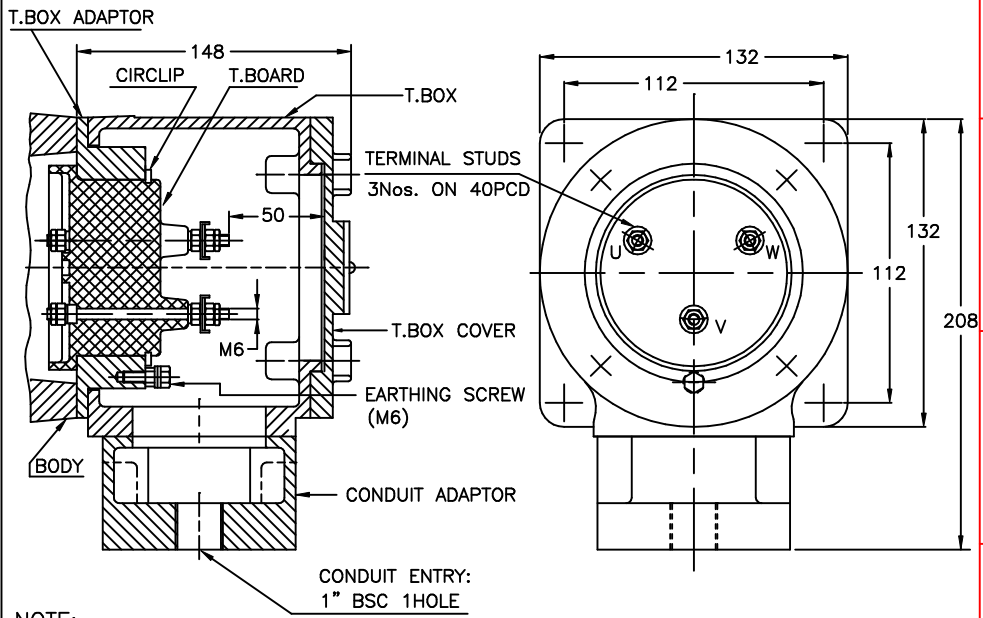

NOTE:-

1) CABLE SIZE :- LE90 & 100 - 1X4CX10Sq.mm (MAX)

SL	Frame	A	AA	AB	ØAC	AD	B	BA	BB	C	D	E	F	GA	GD	H	HA	HD	ØK	L	
1	LE 90S	140	36	176	177	145	100	36	120	56	24	j ⁶	50	8	27	7	90	12	348	10	355
2	LE 90L						125		145												380
3	LE 100L	160	40	200	194	145	140	40	170	63	28	j ⁶	60	8	31	7	100	12	366	12	420

Z122628100JR

THIS SUPERSEDES FROM dt AS PER DCN No.....
 THIS SUPERSEDED BY FROM dt AS PER DCN No.....

MATERIAL SPECIFICATION	RAW MATERIAL SIZE	WEIGHT kg	SCALE
		RM FIN.	

CASTING/FAB REF. _____ No.P.S.: - _____ NTS

USED ON

REDRAWN	CHECKED	STANDARD	APPROVED
Sd/-	Sd/-	Sd/-	Sd/-
dt:22/01/2009	dt:22/01/2009	dt:22/01/2009	dt:22/01/2009

LE90 & 100

TITLE: **DIMENSION SHEET**

32262898R1

SHEET ONE OF ONE

KIRLOSKAR ELECTRIC COMPANY LTD. HUBLI-580030 (INDIA)

